

DIN 7982 C sim. UNI 6955 EN ISO 7050

Vite autofilettante a testa svasata piana con impronta croce H (Phillips), tipo F (senza punta)

Cross recessed H (Phillips) countersunk (flat) head tapping screw, type F (flat point)

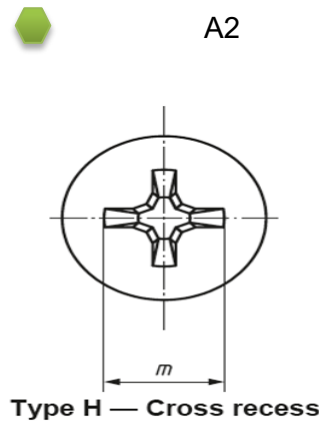
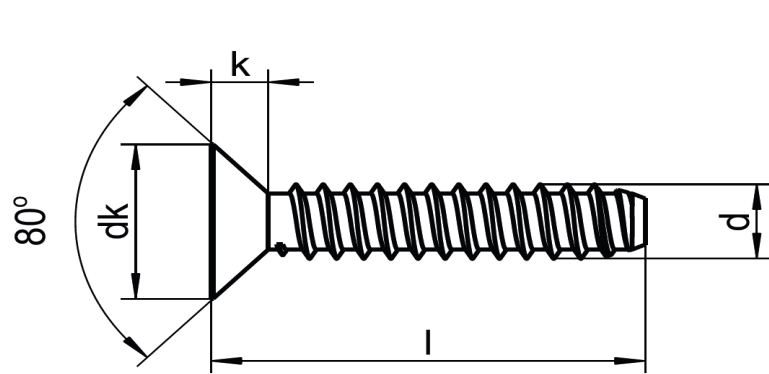

P^1		1,1	1,3	1,3	1,4	1,6	
d_k	max. = nom.size	5,5	6,8	7,5	8,1	9,5	
	min.	5,2	6,44	7,14	7,74	9,14	
k	≈	1,7	2,1	2,3	2,5	3	
Cross recess	Cross recess no.	1	2				
	Type H	m ≈	3	4,2	4,6	4,7	5,1
	Penetration depth	min.	1,4	1,62	2,03	2,11	2,59
		max.	1,7	2,12	2,53	2,62	3,1
d		ST2,9	ST3,5	(ST3,9)	ST4,2	ST4,8	

¹) $P=$ è il passo del filetto / $P=$ is the pitch of the thread.

La misura del filetto tra parentesi è da evitare se possibile / The thread size in brackets should be avoided if possible.

I nom.	min.	max.	ST2,9	ST3,5	(ST3,9)	ST4,2	ST4,8
6,5	5,7	6,5	2,9x6,5				
9,5	8,7	9,5				4,2x9,5	4,8x9,5
13	12,2	13		3,5x13	3,9x13	4,2x13	4,8x13
16	15,2	16				4,2x16	4,8x16
19	18,2	19				4,2x19	4,8x19
22	20,7	22				4,2x22	4,8x22
25	23,7	25				4,2x25	
32	30,7	32				4,2x32	
38	36,7	38					

La misura del filetto tra parentesi è da evitare se possibile / *The thread size in brackets should be avoided if possible.*